

# FULL TIME

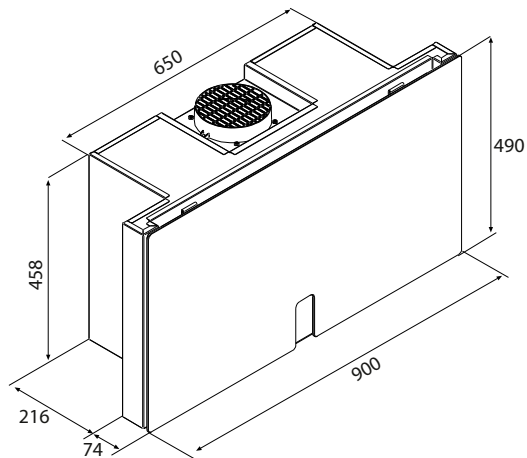

## CARATTERISTICHE FEATURES

**Display con orologio**  
Display with clock

**Vetro satinato**  
Satin glass

**Kit camini optional**  
Chimneys kit optional

**Predisposta per sistema Integra**  
Ready for Integra system

## PRESTAZIONI PERFORMANCE

**Portata IEC** 672 m<sup>3</sup>/h  
IEC air flow

**Livello sonoro** 49/60/66 dB(A)  
Noise level

**Assorbimento totale** 229 W  
Total absorption

## ILLUMINAZIONE LIGHTING

**Lampade** 9 W Led bar  
Lamps

**Temperatura di colore** 4000 K  
Color temperature

**Intensità** 172 Lux  
Intensity

## DATI TECNICI TECHNICAL DATA

**Dimensioni** 90 cm  
Size

**Comando** Display touch a 4 velocità (3+1 intensiva)  
Control Touch display 4 speeds (3+1 intensive)

**Finitura** Nera  
Finish Black

**Dimensione uscita aria** Ø150 mm  
Air outlet dimensions

**Filtri** Filtri grasso lavabili  
Filters Washable grease filters  
Filtri odori optional  
Odour filters optional

## ACCESSORI ACCESSORIES

**Kit filtri odori** Standard AFFCAINTIME  
Odour filters kit Long Life AFFCAFULLTIME

**Kit camini** KCINTIMEF01  
Chimneys kit

## MODELLI MODELS

Full Time BL/A/90

CCFTIME9001



ENERGY CLASS



TOUCH CONTROL



DISPLAY



WASHABLE GREASE FILTERS



LONG LIFE FILTERS



PERIMETER ASPIRATION



DOUBLE ASPIRATION



ELECTRIC HOB MIN. DISTANCE



GAS HOB MIN. DISTANCE



INTEGRA



5 YEARS WARRANTY

