

2-4 MOTORI SOLO 75-90 W  
2-4 MOTORS ONLY 75-90 W



## F161 AXIAL

<b>Portata massima:</b>	4 motori: 850 m <sup>3</sup> /h - 2 motori: 700 m <sup>3</sup> /h	<b>ebmpapst</b>
<b>Livello sonoro:</b>	44/64 dB(A)	
<b>Comando:</b>	Comando touch progressivo a 10 velocità (9+1 intensiva) Avviso saturazione filtri grasso e carbone	
<b>Illuminazione:</b>	2x3,5W Led	
<b>Dimensione:</b>	90x60 cm	
<b>Finitura:</b>	Acciaio inox e vetro nero o bianco	
<b>Filtri:</b>	Filtri grasso in acciaio inox lavabili Filtri carbone inclusi	

### Solo filtrante

<b>Max air flow:</b>	4 motors: 850 m <sup>3</sup> /h - 2 motors: 700 m <sup>3</sup> /h	<b>ebmpapst</b>
<b>Noise level:</b>	44/64 dB(A)	
<b>Control:</b>	Progressive touch control 10 speeds (9+1 intensive) Grease and charcoal filter control	
<b>Lamps:</b>	2x3,5W Led	
<b>Size:</b>	90x60 cm	
<b>Finish:</b>	Stainless steel and black or white glass	
<b>Filters:</b>	Washable stainless steel grease filters Charcoal filters included	

### Recirculation only

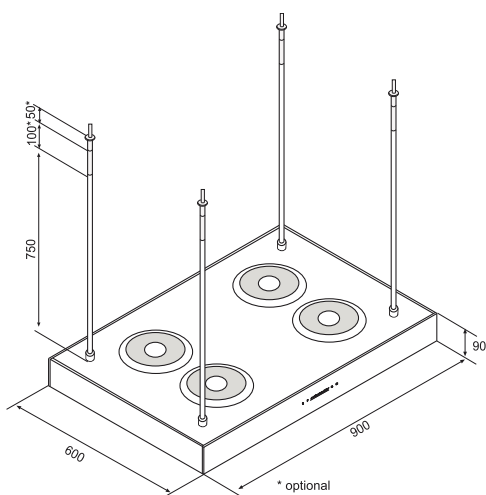

### ACCESSORI / ACCESSORIES

Kit filtri carbone attivi / Active charcoal filters kit  
2 motori / motors: AFFCAF1422M  
4 motori / motors: AFCFCAF142