

## V7

A

<b>Portata massima:</b>	725 m <sup>3</sup> /h
<b>Portata massima IEC:</b>	677 m <sup>3</sup> /h
<b>Livello sonoro:</b>	50/60 dB(A)
<b>Comando:</b>	Elettronico a 4 velocità (3+1 intensiva) Timer Sensore di calore per il funzionamento automatico
<b>Illuminazione:</b>	2x2,1W Led
<b>Dimensione:</b>	60/90 cm
<b>Finitura:</b>	Acciaio
<b>Filtri:</b>	Filtri grasso lavabili Filtri carbone per versione filtrante (optional)

<b>Max air flow:</b>	725 m <sup>3</sup> /h
<b>IEC air flow:</b>	677 m <sup>3</sup> /h
<b>Noise level:</b>	50/60 dB(A)
<b>Control:</b>	Electronic control 4 speeds (3+1 intensive) Timer Heat sensor for automatic functioning
<b>Lamps:</b>	2x2,1W Led
<b>Size:</b>	60/90 cm
<b>Finish:</b>	Steel
<b>Filters:</b>	Washable grease filters Charcoal filters for recirculation mode (optional)

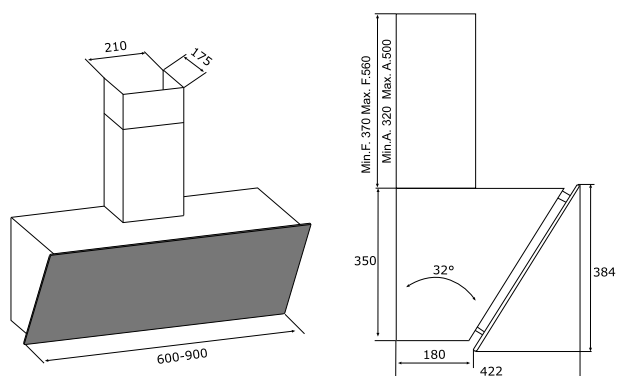

### ACCESSORI / ACCESSORIES

Kit filtri carbone attivi / Active charcoal filters kit  
60 cm AFFCAV60  
90 cm AFFCAV90