

serie COPENHAGEN
CPROX60SRB / CPROX60SX

**40
BOTTIGLIE**

**1 ZONA
5-20°C**

**RIPIANI RIMOVIBILI
"LABEL VIEW"**

**ILLUMINAZIONE
A LED**

**LIVELLO SONORO
38 dBA**



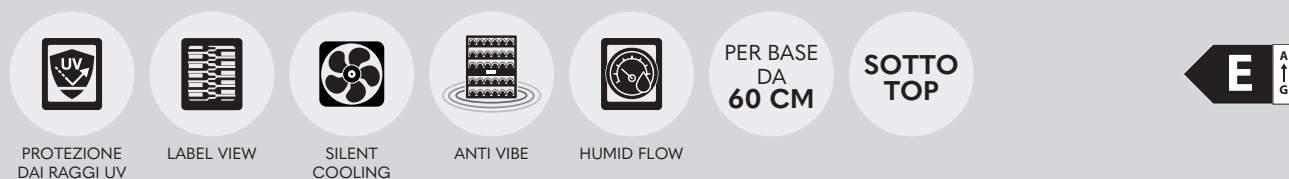

- Incasso sottotop
- Contiene fino a 40 bottiglie
- 1 zona (5-20°C)
- Compressore Inverter
- Livello sonoro: 38 dBA
- A 815 x L 595 x P 585 mm
- Consumi: 83 kWh/anno
- 4 ripiani in metallo "Label View", estraibili
- Porta in vetro anti UV a 2 strati con Argon
- Display digitale
- Luce a LED
- Peso netto: 48 Kg
- Voltaggio: 220-240V
- Lunghezza del cavo di alimentazione: 150 cm



CPROX60SRB
cornice nera



CPRO1X60SX
cornice in acciaio inox

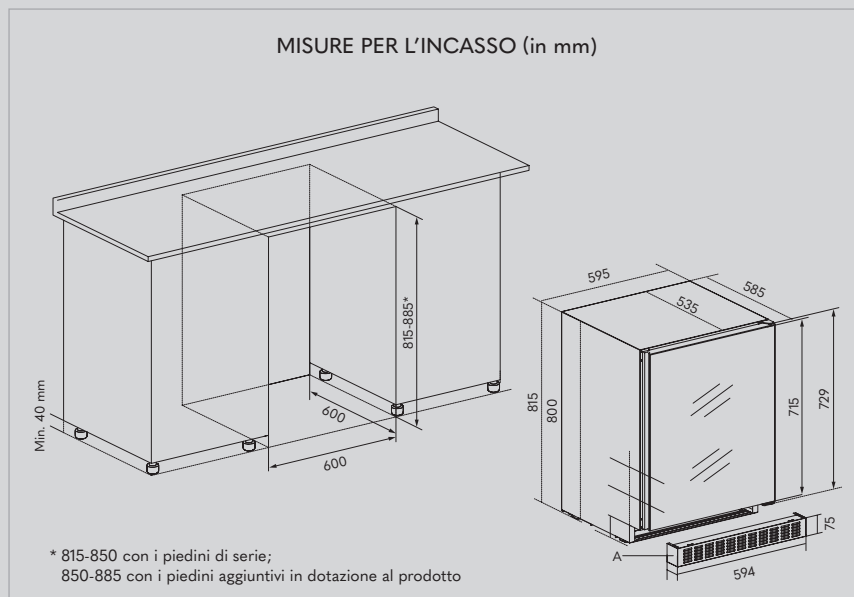

MODELLO	CODICE	FINITURA	PREZZO IN €
CPROX60SRB	4760019	CORNICE NERA	2.520,00
CPROX60SX	4760020	CORNICE IN ACCIAIO INOX	2.620,00